

SERPAC 112

Electronics Enclosures

NOTES:
 1. WHEN MACHINE OR I PLATES MODIFICATIONS ARE REQUIRED,
 USE THE CENTER OF THE BOX TO DIMENSION.

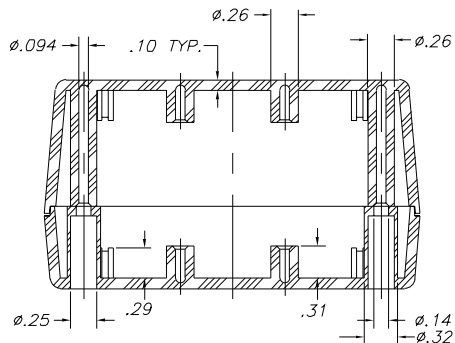
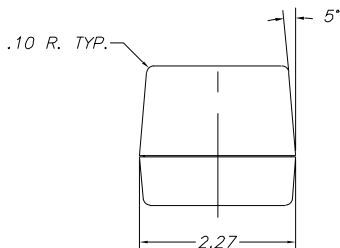
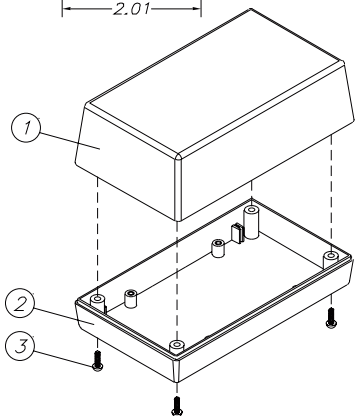
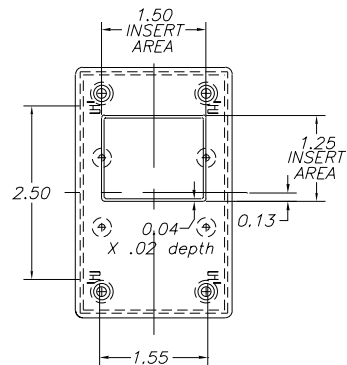
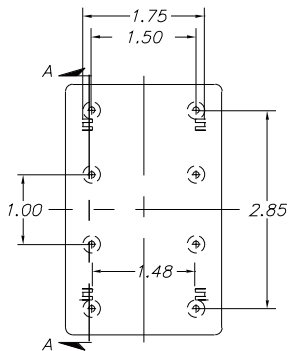
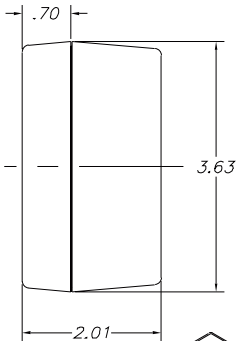

SECTION A-A

8-17-98.

ALL DIMENSIONS ± .010

ITEM	PART NO.	DESCRIPTION	PART NO.	DESCRIPTION
1	12	PLASTIC TOP	50	FEET
2	11	PLASTIC BOTTOM	310	PROTOTYPE GRID BOARD (HORIZ.)
3	6005	SCREWS (4)	410	PROTOTYPE CLAD BOARD (HORIZ.)
			312	PROTOTYPE GRID BOARD (VERT.)
			412	PROTOTYPE CLAD BOARD (VERT.)
			PS-11	PERIMETER SEAL
			PC	POCKET CLIP